

Public Warning System

Executive Summary

Introduction

Natural and human-made disasters put the lives and property of citizens at risk. **Public Warning System (PWS)** services enable government agencies to broadcast timely and accurate alerts, warnings and critical information that will help citizens take appropriate action to protect themselves and their property during emergencies.

In 2006, the 3GPP standards body began to define technical specifications and requirements for PWS services. The resulting specification document (3GPP TS 22.268) sets global criteria for the delivery of alerts, the content of messages and the nature of features for PWS-capable handsets.

Based on this standard, governments around the globe (including the US, Netherlands, Chile, Japan, Korea, Canada and Israel) have deployed emergency alerting services.

In December 2018, the European Parliament issued the following directive: “By 21 June 2022, Member States shall ensure that, when public warning systems regarding imminent or developing major emergencies and disasters are in place, public warnings are transmitted by providers of mobile number-based interpersonal communications services to the end-users concerned.” For many European countries, the time is now to start implementing PWS services that will fulfill this directive.

PWS architecture and implementation options

As shown in Figure 1, emergency alert messages are issued by government agencies through the government’s alert management system (AMS) and sent to mobile network operator (MNO) networks for broadcast to one or more targeted geographic areas.

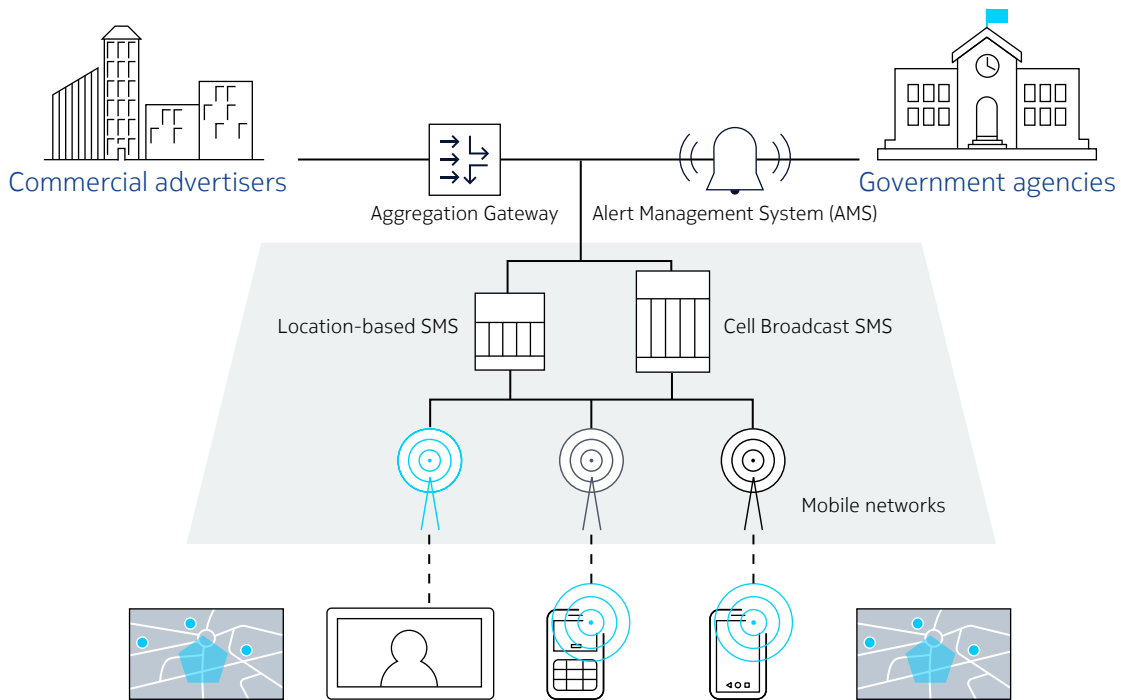

Figure 1. Public Warning System global architecture

Nokia PWS solution

The Nokia PWS solution provides all the capabilities required to support the government AMS and both of the primary technologies that MNOs can use to deliver PWS alerts: Cell Broadcast Service (CBS) and location-based SMS (LB-SMS).

Government AMS

Governments use the AMS to manage emergency alerts. The Nokia AMS is made up of an alert management portal and an alert gateway.

The alert management portal gives government emergency authorities the tools they need to:

- Define the geographical zones that require public alerts
- Create and manage alert messages
- Perform analysis and reporting on the emergency campaign, including running diagnostics to determine exact delivery time and what caused failures

The alert gateway supports alert origination and authentication, maintains MNO profiles and ensures delivery of alerts. It also acts as a gateway across the multiple mobile networks connected to the PWS.

CBS solution

Nokia Broadcast Message Center (BMC) enables governments and MNOs to use CBS technology to broadcast warning alert messages to mobile devices in a specific geographic area. BMC complies with PWS standards and enables MNOs and wireless service providers to meet government mandates for emergency broadcast services as defined in various countries.

BMC is a mission-critical product designed to help save lives and property during national and regional emergencies. It supports message delivery over any generation of mobile network (GSM, UMTS, LTE, 5G and CDMA). Nokia is the market leader in Cell Broadcast Center (CBC) deployments for emergency alerting services.

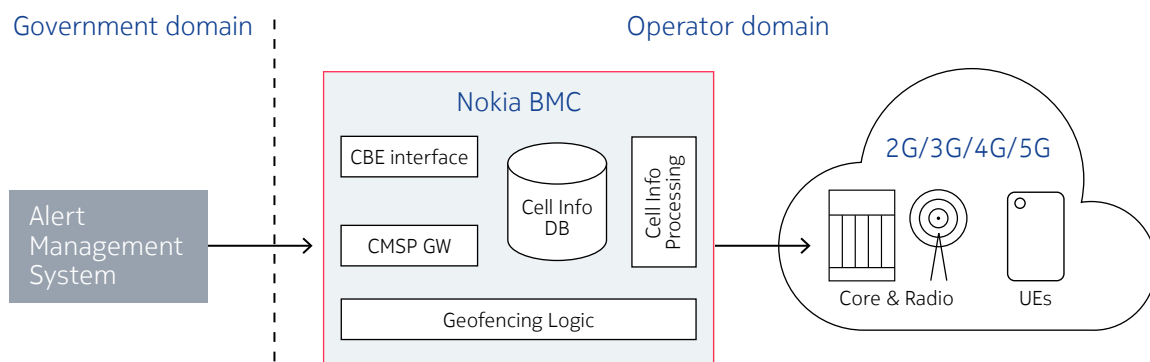

Figure 2. Nokia CBS solution architecture

BMC can also enable MNOs to use CBS to support revenue-generating commercial services such as information alerts, community and campus alerts, and mobile advertising. This creates an incentive for MNOs to implement a PWS solution beyond simply obeying a law.

Based on the 3GPP and ETSI specification documents and experience gained from early PWS implementations, CBS is the most effective technology to reach large areas and populations.

LB-SMS solution

The Nokia LB-SMS solution allows the addition of SMS communication with situational awareness capabilities that leverage location-based server (LBS) information. This solution relies on the Nokia Location Server (NLS), which determines the geographical position of mobile devices and sends this information to the LB-SMS server. The LB-SMS server then sends the alert message to devices located in the warning area defined by government authorities.

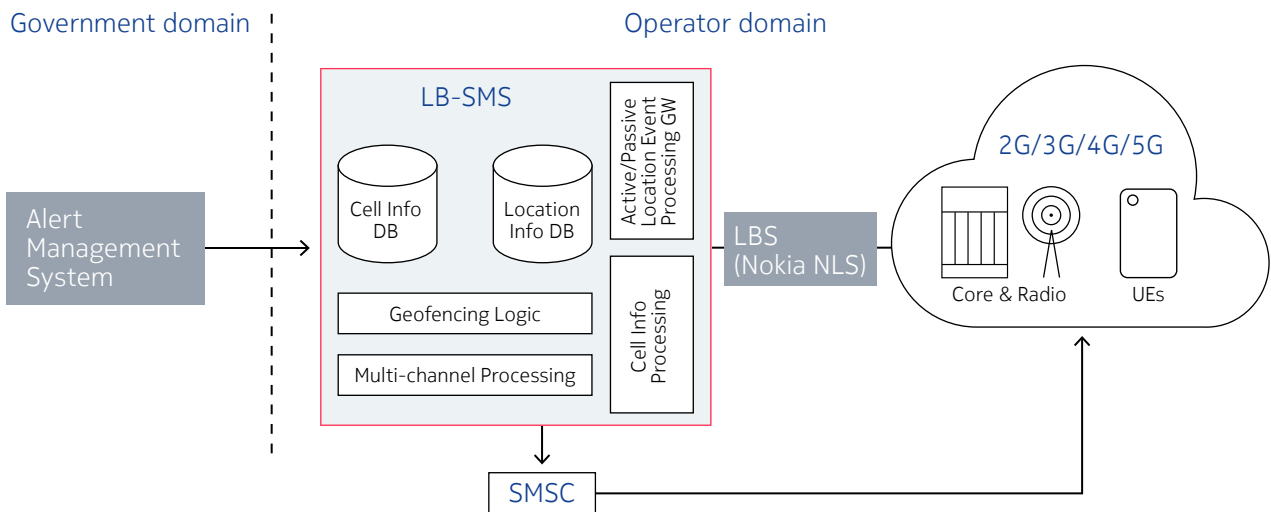

Figure 3. Nokia LB-SMS solution architecture

Get the best of both worlds

CBS is the most effective technology for PWS, but LB-SMS offers several important benefits, including:

- Enhanced situational awareness for emergency authorities
- Support for two-way communication
- The ability to identify the current location of the affected people to assist in rescue operations

Nokia recognizes the complementary nature of CBS and LB-SMS. It provides governments and MNOs with a PWS solution that includes both platforms as well as the associated integration services. This approach maximizes the efficiency of the PWS service, speeds up nationwide deployment and guarantees end-to-end interworking of the solution.



Why choose Nokia for PWS?

- One-stop shop: Nokia provides an end-to-end solution that includes full AMS, CBS and LB-SMS capabilities. It is a one-stop shop that covers government and MNO requirements for PWS services.
- Standards-compliant: Nokia offers a feature-rich solution that complies with all possible wireless emergency alert standards (3GPP, ATIS, ETSI).
- Telco expertise: Nokia is the only vendor with end-to-end wireless network expertise that includes the core and RAN. It is also the vendor with the most LTE deployments in large Tier 1 operator networks. The PWS solution leverages Nokia 5G/LTE solution and IoT testing, a major factor in helping Tier 1 operators identify network issues. Nokia's 5G PWS solution is available and being deployed by a US Tier 1 operator.
- Proven solution: The Nokia PWS solution is in service with top Tier 1 operators in the US, Canada, Europe, Central America and Latin America. It has also been deployed and tested with multiple major network vendors.
- Scalable and industrialized: Nokia provides a scalable PWS solution that meets growing capacity demands and supports rapid cell growth. The unique capabilities and features of the BMC product accelerate use case development.
- Comprehensive professional services: The Nokia PWS solution comes with a package of integration services that enable governments and MNOs to define, design, deploy and test the solution across their networks with all stakeholders involved.

About Nokia

We create the technology to connect the world. Only Nokia offers a comprehensive portfolio of network equipment, software, services and licensing opportunities across the globe. With our commitment to innovation, driven by the award-winning Nokia Bell Labs, we are a leader in the development and deployment of 5G networks.

Our communications service provider customers support more than 6.4 billion subscriptions with our radio networks, and our enterprise customers have deployed over 1,300 industrial networks worldwide. Adhering to the highest ethical standards, we transform how people live, work and communicate. For our latest updates, please visit us online www.nokia.com and follow us on Twitter [@nokia](https://twitter.com/nokia).

Nokia is a registered trademark of Nokia Corporation. Other product and company names mentioned herein may be trademarks or trade names of their respective owners.

© 2020 Nokia

Nokia Oyj
Karakaari 7
02610 Espoo
Finland
Tel. +358 (0) 10 44 88 000

Document code: SR2006045087EN (June) CID207390